

Hybrid Heat Pump Geothermal System

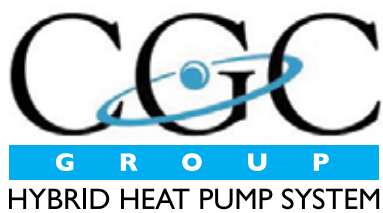

Energy
in Motion



CGC Hybrid Heat Pump Geothermal Operation

The CGC Group Hybrid Heat Pump System is a novel combination of traditional commercial HVAC building technologies. The units combine conventional water cooled air conditioning and warm water space heating in one package. They operate as fan coils in heating and heat pumps in cooling. The compressors never operate in the heating mode. They can cool or heat any space at any time of the year. Hybrid Heat Pumps are provided with fluid which varies in temperature depending on outdoor air temperature. As the ambient conditions get colder, the fluid temperature is increased.

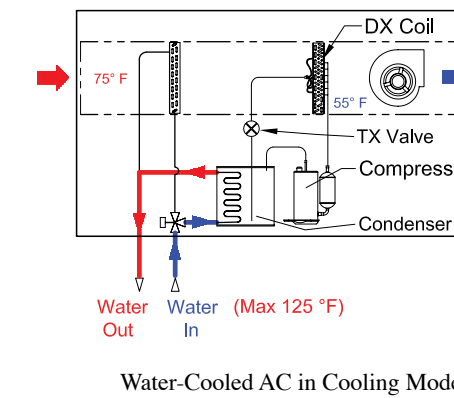
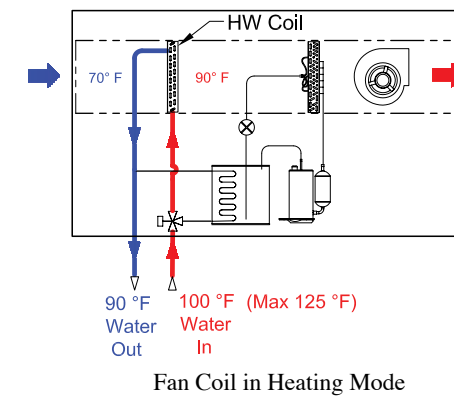

Cooling

- Fluid is circulated through the building interior heat pump loop and also through the geothermal loop.
- Heat rejection takes place directly to the geothermal loop.

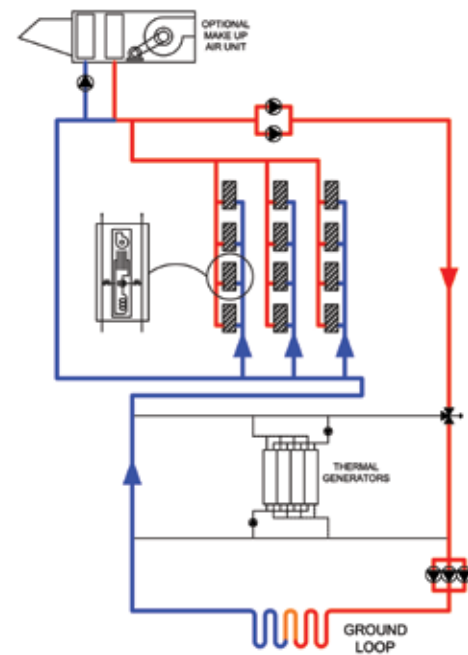

Cooling Mode

Balanced

- Fluid is circulated only through the building interior heat pump loop.
- No Injection/Rejection required.
- Can result in 38% ++ reduction in heating energy.

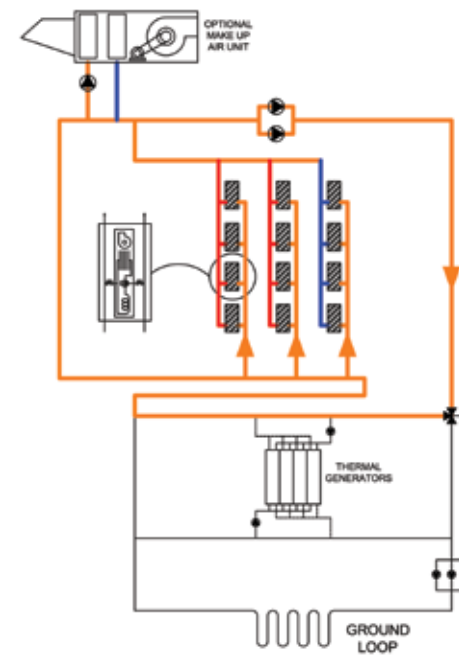

Balanced Operation

Heating

- Fluid is circulated through the building interior heat pump loop and also through the geothermal loop.
- Heat injection is provided for instantaneous load only by Compaq water to water heat pumps.

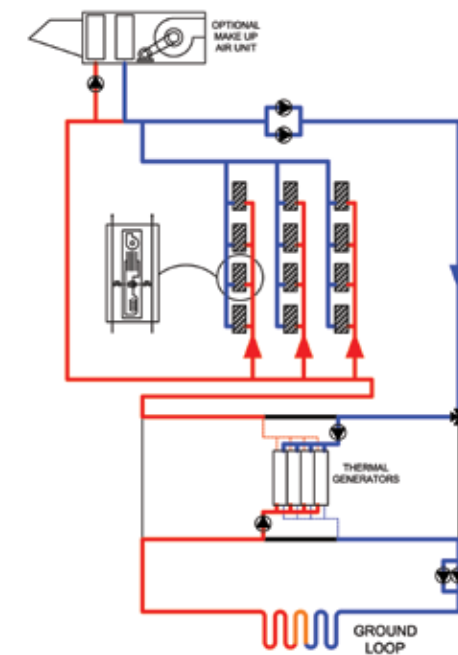

Heating Mode

- Warm fluid is delivered to hydronic heating coils located in the CGC Hybrid Heat Pump.
- The air to water heat pumps in the heating mode do not operate any compressors.

Recharging the earth's thermal mass...

- Fluid is circulated directly from the heat pump loop to the geothermal loop.
- Heat rejection takes place in ground loop during off peak conditions.
- Geothermal loop can be recharged off peak by optional heat rejector. (Fluid cooler).

CGC Group Geothermal System Advantages

- Air to water Heat Pump units are sized for standard operation, not oversized for geothermal operation.
- Insulation is not required on heat pump loop.
- Compax water to water heat pumps are staged to the instantaneous load which minimizes electrical consumption.
- Heating the building with excess heat (**FREEHEAT™**) during balanced operation minimizes the amount of heat rejected to the earth loop. This results in less stress on the earth's thermal mass and can provide 38% ++ reduction in heating energy requirements.
- Recharging of the earth's energy mass can take place during off peak hours.
- Compax water to water heat pumps can produce 140 F fluid for use in various building heating loads (radiant floor heating, air make up, etc). This also serves to remove heat from the earth loop in order to return the thermal mass to balanced conditions.

CGC Group Hybrid Heat Pump Advantages

- High EER's, due to unidirectional refrigerant flow and no reversing valves.
- Low flow rate of 2 gpm/ton vs 3 gpm/ton will result in lower pumping energy as well as smaller pipe sizes and possibly smaller pumps.
- Very quiet operation with compressor operation (cooling) or without compressor operation (fan coil sound levels on heating).
- Delivers better heating comfort with "on demand" fan coil operation as opposed to full compressor heating.
- Less compressor operating time equals less maintenance and longer life.

FREEHEAT™

The process of reclaiming the heat within a building to directly satisfy it's own heating requirements without additional energy input.

Geothermal Savings

An independent analysis by Caneta Energy confirms that a Hybrid Heat Pump Geothermal System installed in the Springdale Professional Building will result in 23.8% energy savings over a conventional GSHP system.

"Caneta Energy has modeled heat pump systems in a significant number of buildings over the past number of years. We have seldom seen a concept as promising as the CGC Group hybrid system particularly when used in a ground coupled system with water to water heat pumps between the building loop and ground heat exchanger. When the building is balanced thermally, the ground heat exchanger can be by-passed, to maximize heat recovery and minimize pumping. This provides the benefits of conventional water-loop and ground source concepts in one system."

Caneta Research Inc
R.L. Douglas Cane, P.Eng, Principal

April 24, 2007

System type	HVAC Only (Annually)		ENTIRE Building (Annually)	
	Energy Use (KWh)	Operating costs (\$)	Energy Use (KWh)	Operating costs (\$)
Conventional GSHP	619,963	\$55,169	1,577,827	\$143,056
CGC Hybrid	472,309	\$43,311	1,430,280	\$131,198
Savings	147,654 (23.8%)	\$11,858 (21.5%)	147,547 (9.4%)	\$11,858 (8.3%)

Le Vistal

L'Ile-des-Sœurs, Montréal, Québec.

25 stories, 2 towers.
330 CGC Hybrid Heat Pumps.
14 Compax Water to Water Heat Pumps.
Geothermal application, R-410A,
LEED certified.



Springdale Professional Building

Brampton, Ontario, 120,000 sq.ft..

113 CGC Hybrid Heat Pumps.
8 Compax Water to Water Heat Pumps.
Geothermal application, R-410A.
Varizone by CGC.
EC motors, 2 stage compressors.



In cooling dominated buildings, the Compax heat pumps can make use of the excess heat from the earth loop. The CGC Hybrid Heat Pump System with **FREEHEAT™** allows this heat to be used throughout the entire building. This will help balance the annual heat gains and keep the ground loop from overheating.

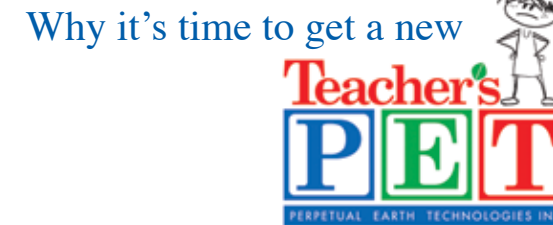

Removable Chassis Cabinet

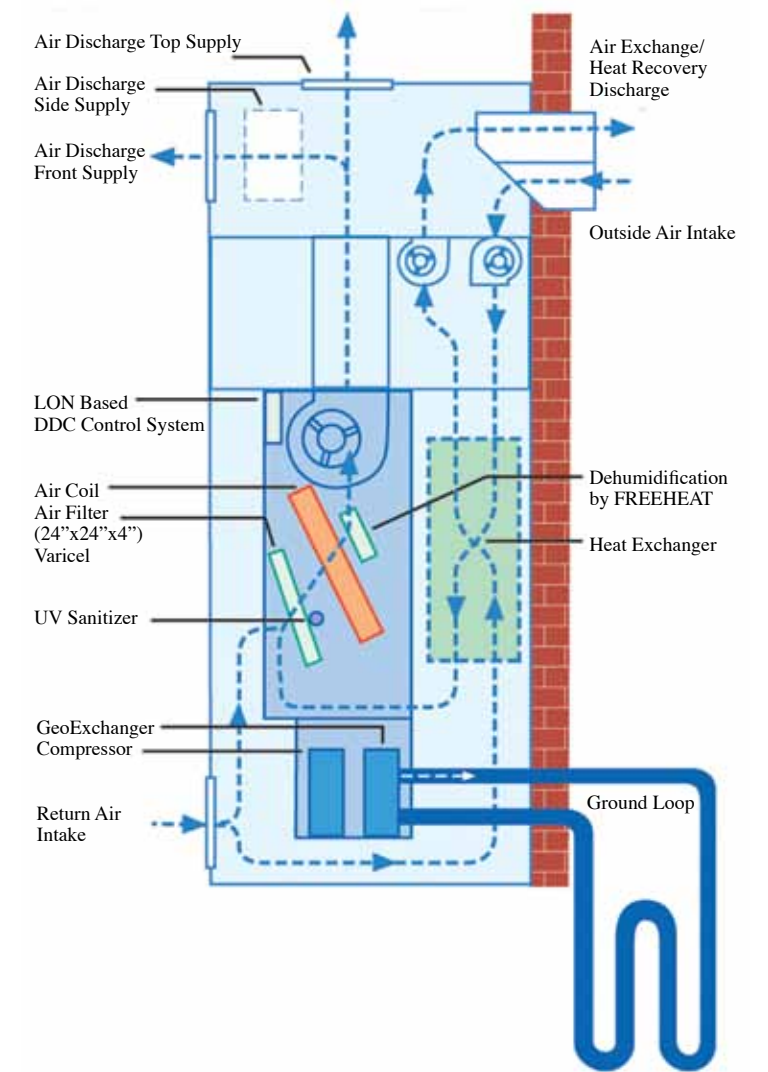

Compax

- Chilled fluid down to 40° F.
- Heating fluid up to 140° F.
- Source fluid from 25° F to 120° F.
- Modular design (13" wide x 58" high x 32" deep = 12.5 tons).
- R 410A.
- Reversing and Non-reversing.
- Staged units control and BAS integration.



Geothermal Classroom Heat Recovery Ventilator

- Geothermal - Reduce Energy.
- Heat Recovery - Recycle Energy.
- **FREEHEAT™** - Reuse Energy.
- Quiet.
- Complete removable chassis.
- Easily retrofitted into existing schools.

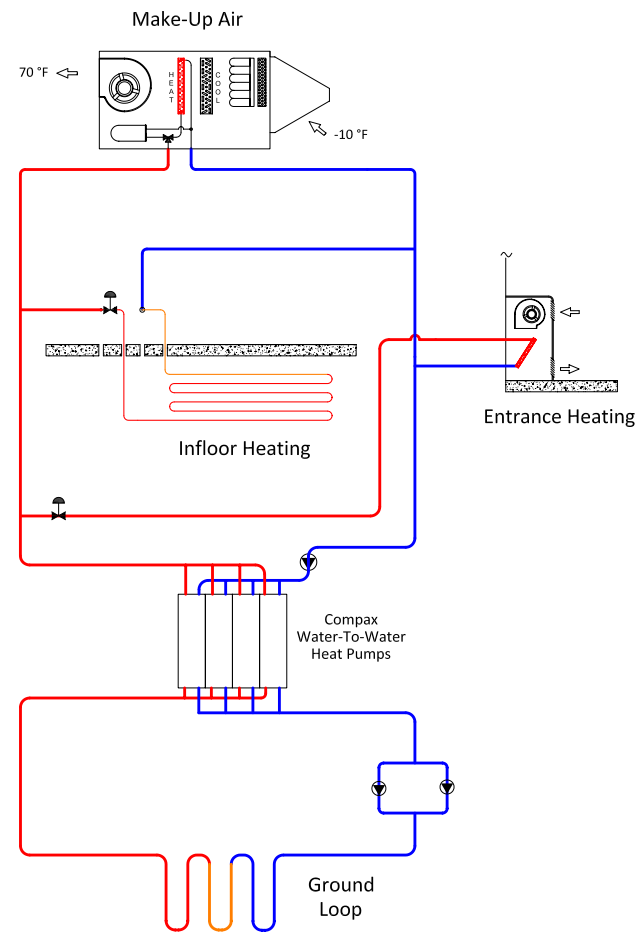

CGC Group Inc., 150 Britannia Road East, Unit #1
Mississauga, Ontario, Canada L4Z 2A4, Tel: 905.568.1661, Fax: 905.568.2839

www.cgc-group.com

